

# Vibro-JR

## ANTI-VIBRATION JACK-UP RUBBER MOUNT with REGUFOAM for CONCRETE FLOATING FLOORS

### Description

**Vibro-JR** is an advanced vibration control system for raised concrete floating floors. It consists of a metal shell that contains the antivibration polyurethane elastomer Regufoam sheet which absorbs the vibrations. The poured concrete does not touch the supporting floor and so the sound bridge between the floating and the supporting floor is avoided. It's very easy to install, allows regulation of height and helps to avoid the use of remaining plywood forms. It also creates an air gap, which is beneficial for the sound insulation and the vibration control.

### Installation

- Place a polyethylene sheet under and round all the surface of the concrete floating floor.
- Isolate the floating floor from building structure, with a suitable antivibration board, between the floating floor and the wall
- Place the antivibration mount Vibro - JR.
- Insert the elastic tube, covering the screw. Cut the elastic tube in a suitable length, so it is greater than the thickness of concrete slab.
- Calculations of the concrete's quality, adequate reinforcement and requirements must be done from a Civil Engineer. Place reinforcing structure of the slab and pour the concrete. Allow the concrete to mature a few days
- Load progressively and uniform the rubber mounts turning clockwise the elevation mechanism using an appropriate female hexagon hand operated socket in order to jack-up the concrete floating floor.
- Place cover tap, if necessary.

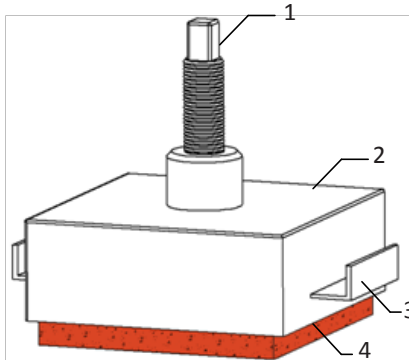

1. Regulation - elevation mechanism.
2. Cover Plate.(Galvanised Metal Sheet)
3. Concrete reinforced holding.
4. Rubber mount Regufoam

### Vibro-JR Selection Table

TYPE	MAXIMUM LOAD (kp*)
Vibro-JR.100	100
Vibro-JR.200	200
Vibro-JR.400	400

\*1 kp = 10 N

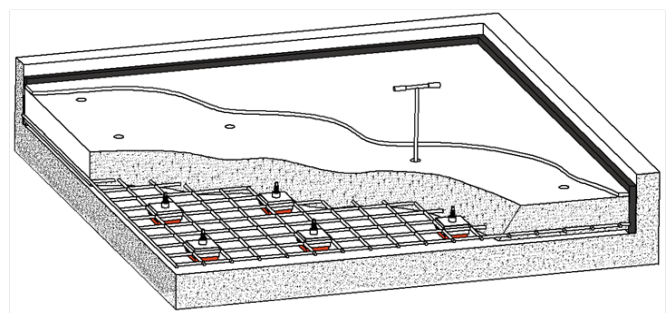
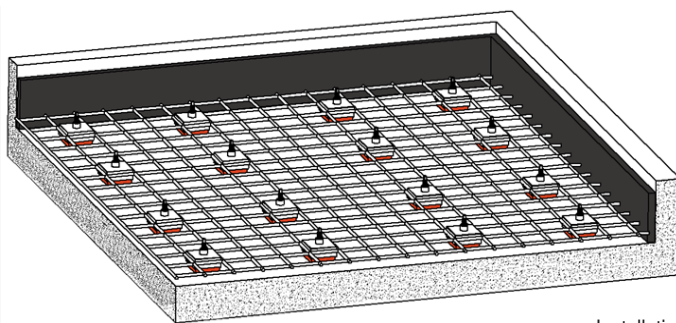

Installation procedure

Design and Production according to Quality Management System ISO 9001.2008 & Environmental Management System ISO 14001.2004