

Vibro-HH

HEAVY SPRING ANTIVIBRATION HANGERS

with Regufoam Vibration Plus

APPLICATIONS

Vibro-HH can be used as:

- Antivibration suspension of machinery (fans, AHUs, Compressors, etc)
- Anti-vibration suspension of pipes or airducts
- Suspension of loudspeakers (line array)

DESCRIPTION

The frame of **Vibro-HH** is made from galvanized metal sheet or metal with painted finish. The Suspension Screw/rod can vary depending on application needs (not included).

Acceptable rod misalignment up to 30° arc, without contacting metal frame.

The elastic element of the hanger is a high quality polyurethane foam, with semi-closed cells, manufactured by the German company BSW under the trademark **Regufoam Vibration Plus®**.

Vibro-HH can be supplied with a preloading kit (rubber & metal washer) upon request.

Different types of hanging endings can be provided (screw/rod, eye bold, etc.)

SELECTION TABLE

To expand the load range of the antivibration hanger **VIBRO-HH** different types are available.

TYPE	MAXIMUM LOAD (kp)*
Vibro HH-250	250
Vibro HH-500	500
Vibro HH-750	750

*(1kp = 10 N)

DYNAMIC CHARACTERISTICS

Deflection (at maximum load) : 25 mm

Natural Frequency (at maximum

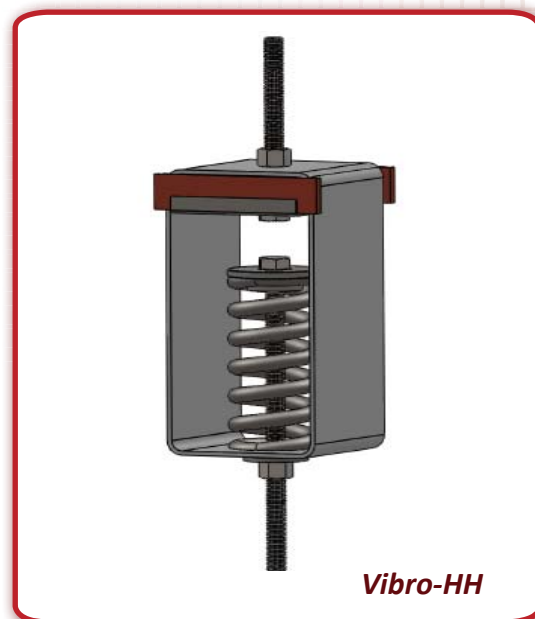

Vibro-HH

Sides View

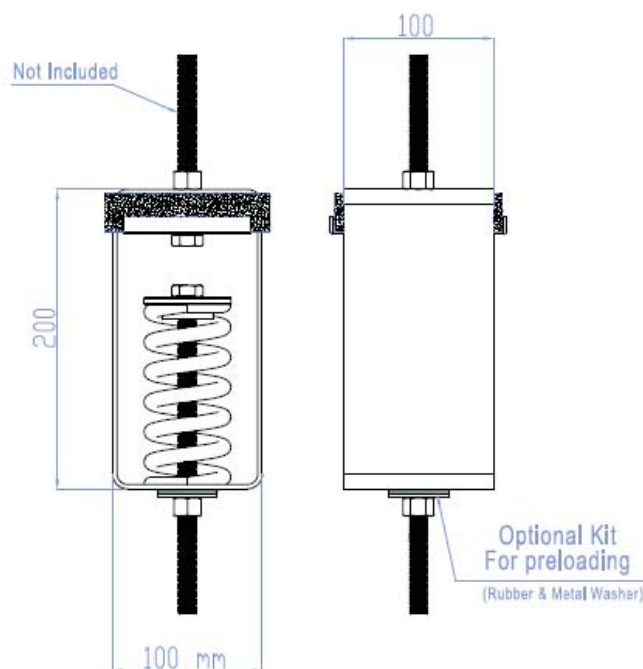

Design and production according to International Standards ISO 9001.2008.

ALPHA ACOUSTIKI LTD

73 Apostolopoulou St. Chalandri 15231 Greece

T: +30 210 6779875 - F: +30 210 6779269

www.vibro.gr - info@vibro.gr